

**BECKHOFF** New Automation Technology

PC-based control  
for the automotive industry

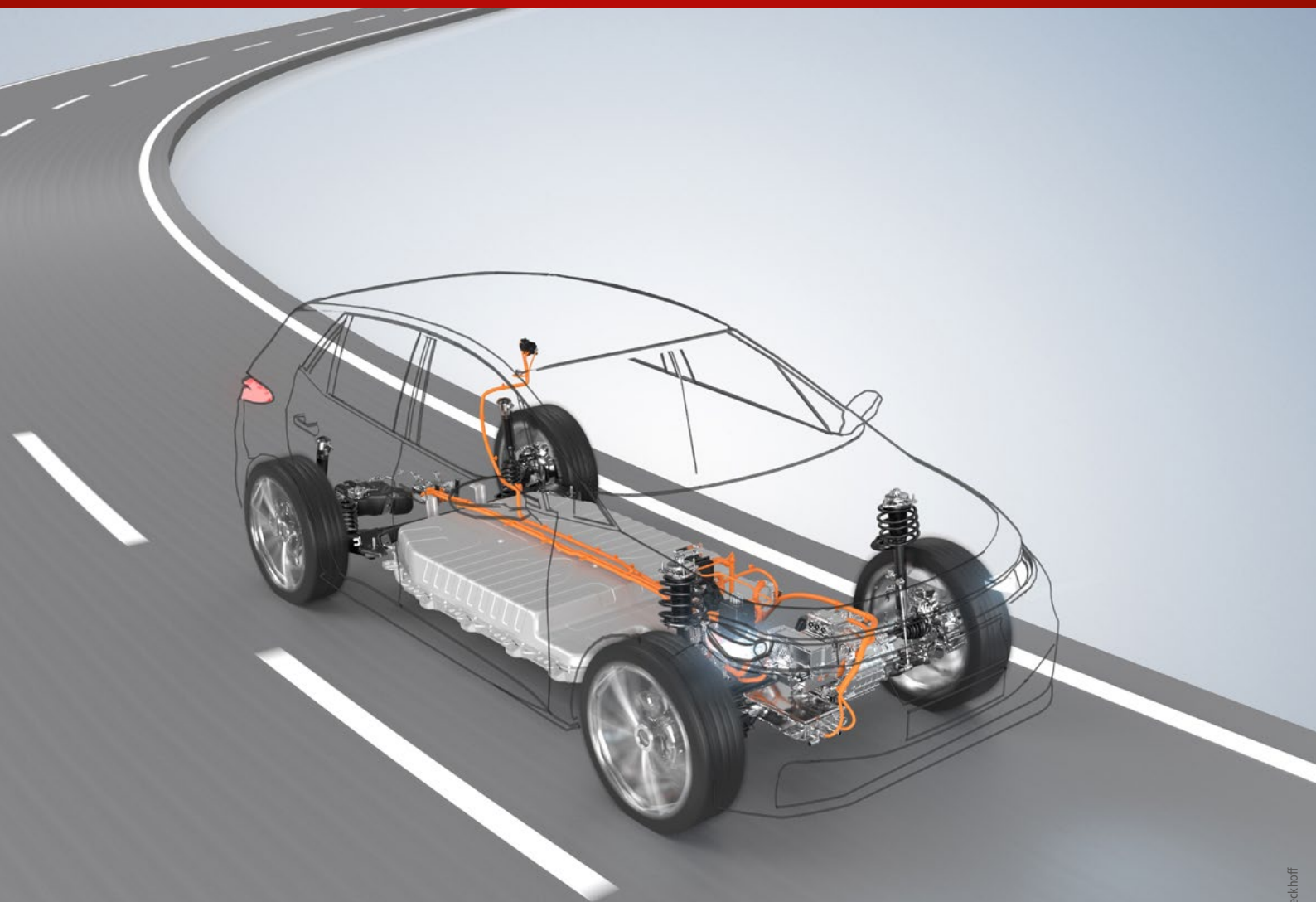

Put your trust in technical expertise: With PC-based control from Beckhoff

**All control functions on a single platform**  
 As a pioneer of PC-based automation and the inventor of EtherCAT, Beckhoff has been behind many milestones in the automation world. Our continuous technological innovations have played a major role in making PC-based control technology a global standard today. By abstracting automation functions from control hardware, PC-based control handles all machine functionality in software: the PLC, HMI, motion control, safety, condition monitoring and so on run on a PC platform, achieving optimum synchronization of all processes.

Our PC-based control technology is based on powerful industrial PCs, the high-speed EtherCAT fieldbus, an extensive I/O portfolio for connecting sensors and actuators, TwinCAT automation software, and the MX-System for control cabinet-free automation. Our modular system is supplemented by drive technology components in all performance classes and designs as well as our intelligent transport systems, XTS and XPlanar. A scalable and modular product portfolio is available for every control task, allowing you to use individual components or configure a complete system solution depending on the

application requirements. This approach enables both centralized and decentralized control architectures in the field.

We've focused on the convergence between IT and the automation environment at a very early stage by implementing globally accepted standards, paving the way for built-in cloud connectivity and intelligent production concepts. Leveraging the high performance of modern processors, which we install in all of our industrial PC series, even computationally intensive applications can be easily integrated into the Beckhoff control platform.

**Sustainability and global availability**  
 Our innovative products and technologies form the basis for sustainable production and the efficient use of resources. The long-term availability of our components also ensures reliable, lasting investment protection. As a carbon-neutral company, we also emphasize the sustainability of our own production processes. We rely on efficient energy management systems, 100% green electricity, and short supply routes by producing our components in-house in Germany.

As a family-run company with decades of experience in automation, you can always

depend on high-quality standards from Beckhoff. We are represented in over 75 countries around the world and support our globally active customers with fast service and local technical support in their local language.

► [www.beckhoff.com/company](http://www.beckhoff.com/company)

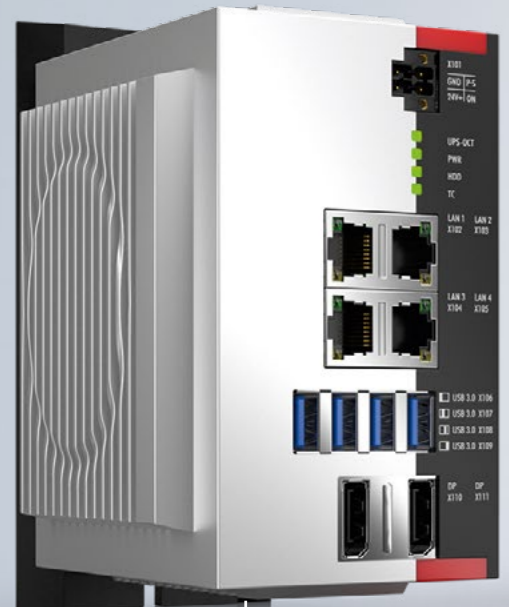

IPC

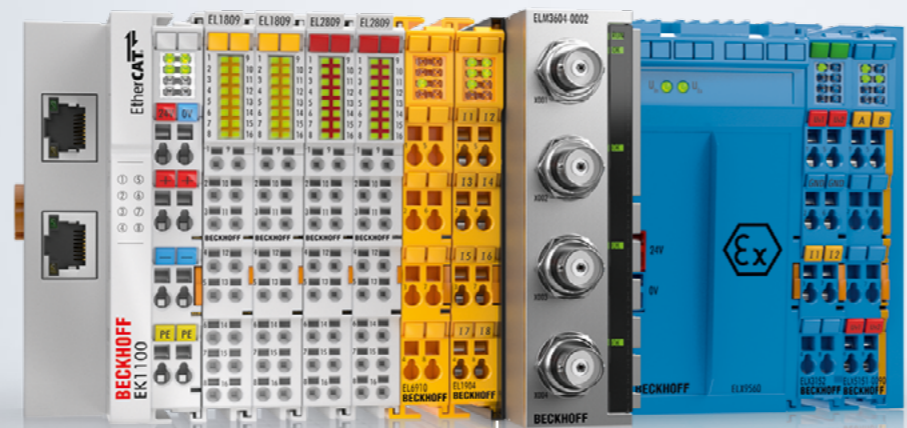

I/O

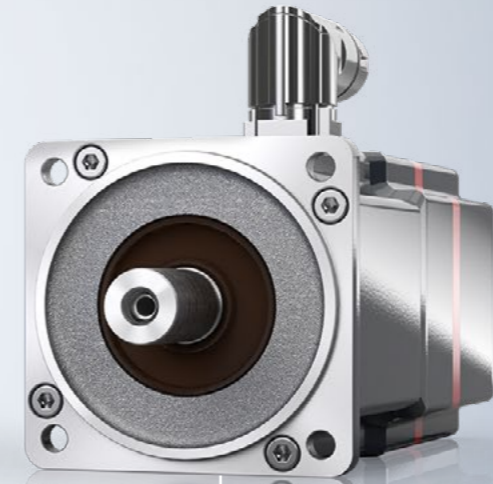

Motion



Automation

# PC-based control for car manufacturing

PC-based control technology from Beckhoff is ideally suited to the complete automation of many complex processes in automotive production: from press control and welding in car body manufacturing to the production of batteries and engines for electric vehicles. Rapid cycle times and a high degree of scalability ensure that you are ideally prepared for the electric vehicle revolution with PC-based control. Flexibility and openness, in both software and hardware, facilitate simple functional extensions, changes and retrofits – major advantages given shortened product life cycles and increased variant diversity.

Integrating all control functions on a central PC platform ensures efficient interaction between all components as well as maximum productivity. Frictional losses or latency times, which occur when different systems communicate, are avoided. At the same time, PC-based control enables you to benefit from cost advantages by eliminating hardware and reducing installation and maintenance work. A wide range of interfaces and support for all common fieldbus systems and software protocols guarantee consistent horizontal and vertical communication, starting with the networking of individual machines in the field right up to

networking at the IT level and into the cloud. EtherCAT's high level of compatibility ensures simple integration of many different devices – even from third-party suppliers – into the control system. This gives you maximum flexibility in your machine design.

With many years of experience in body construction and tire production, along with process, assembly and material handling technology, you can rely on our in-depth technical expertise. As a close partner of global automotive manufacturers, machine builders and automotive suppliers, we also actively promote the standard-

ization of machine communication in working groups such as the VDMA Battery Production Department.

► [www.beckhoff.com/automotive](http://www.beckhoff.com/automotive)



Beckhoff also offers integrated automation solutions for warehouse logistics.

## Tire production

High-performance and compact control technology for the tire and rubber industry

## Test bench technology

Flexible integration of measurement and test technology into the control platform

## Body in white

Proven and powerful automation solutions for press control in sheet metal working

## Components

Control systems to produce electronic components such as sensor technology or lamps

## Assembly

Precise robot control for all handling tasks in production and assembly

## E-motor production

Intelligent automation solutions for stator production with hairpin or winding processes

## Battery production

Flexible and efficient automation of battery production machines

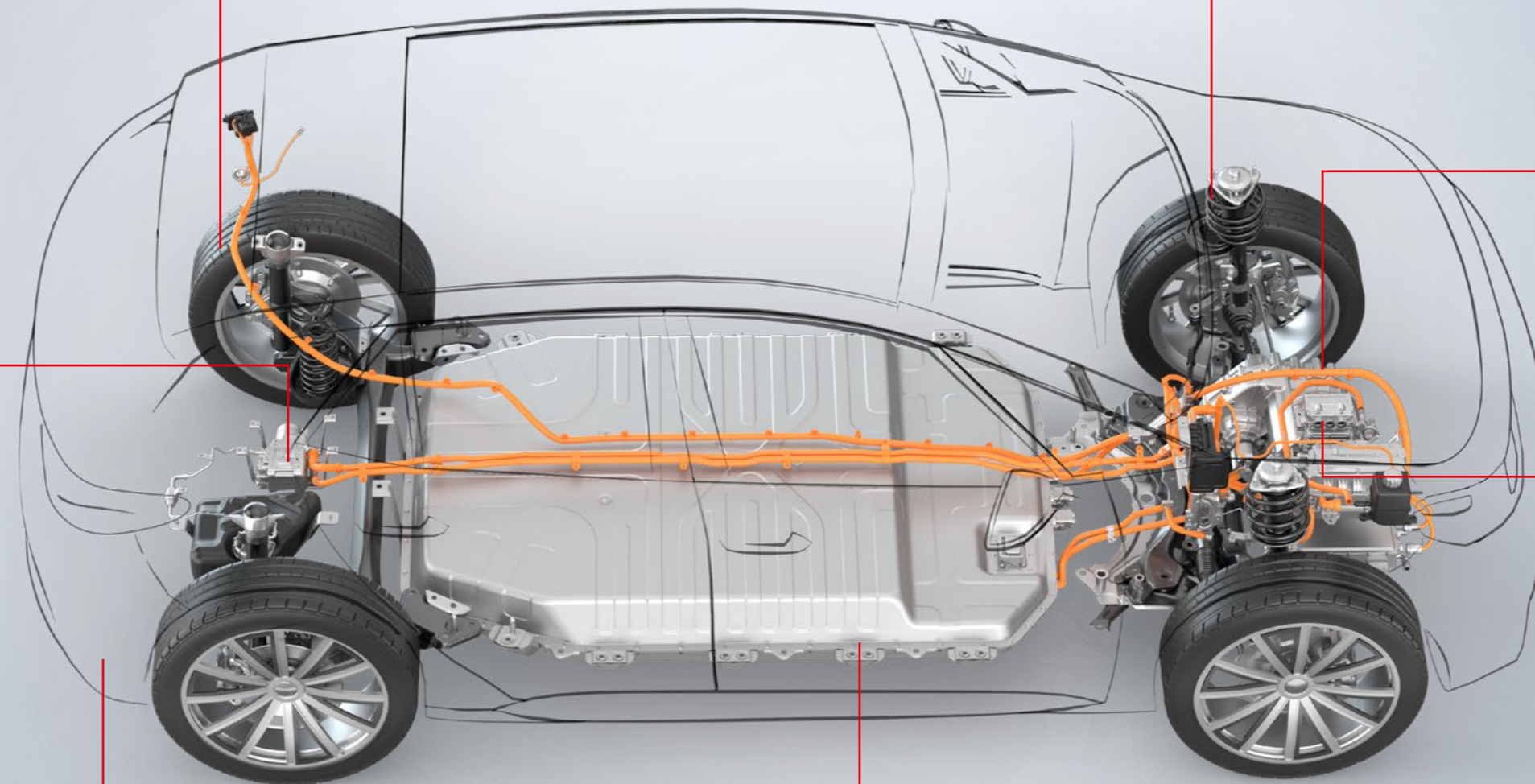

# Automation solutions for battery manufacturing

The fast-growing e-mobility market places high demands on battery cell production in terms of speed and efficiency. This is why intelligent, high-performance automation solutions are so essential. Our control technology enables end-to-end automation of all processes in battery manufacturing: from coating of the electrode foils through to electrolyte filling and testing of the cells. PC-based control offers advantages for all machine types, no matter whether you produce round, pouch, or prismatic battery cells.

► [www.beckhoff.com/battery-production](http://www.beckhoff.com/battery-production)

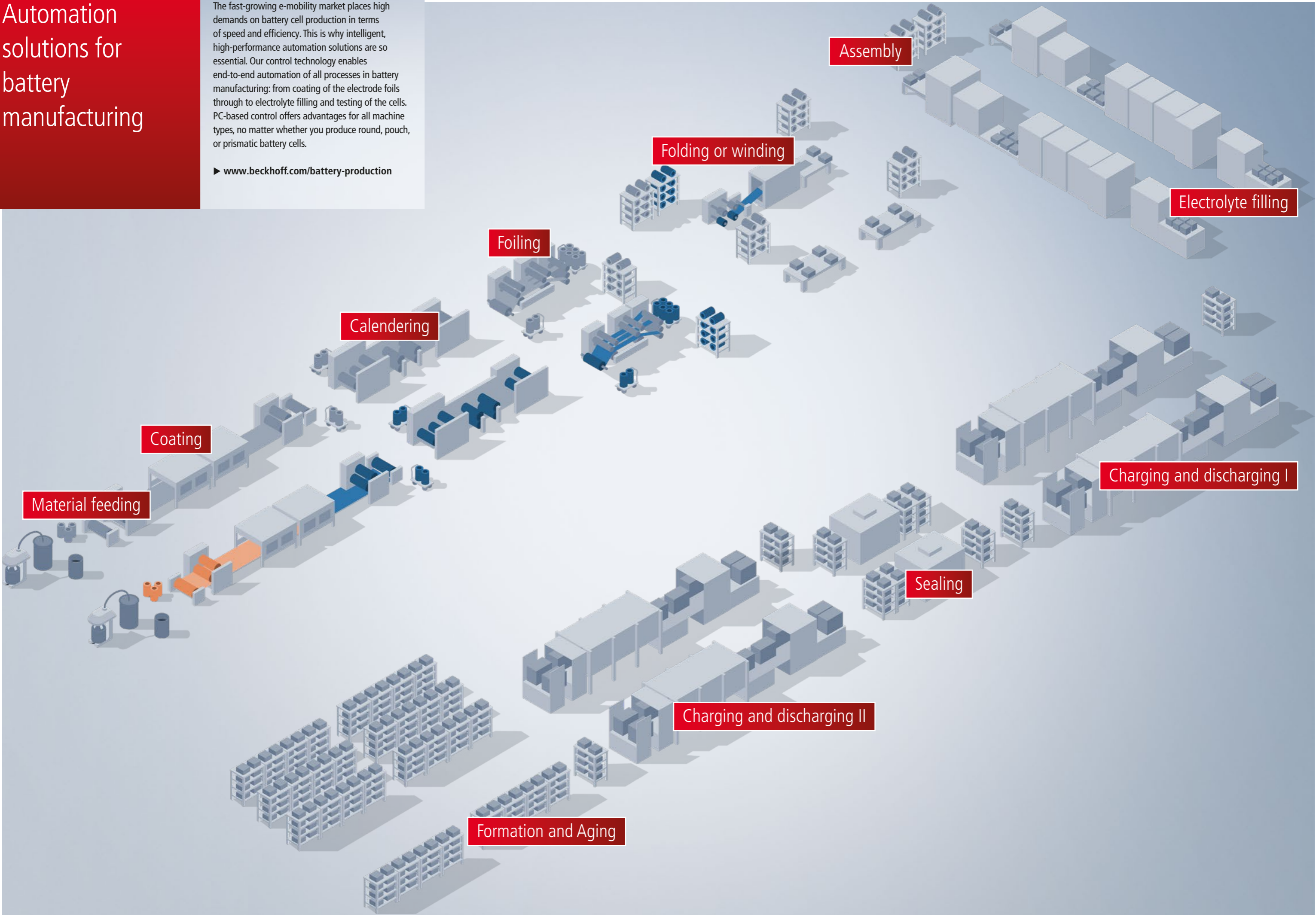

# Automation solutions for battery manufacturing

## Your head start in battery manufacturing with Beckhoff:

- high speed thanks to fast cycle times
- optimal synchronization of control functions on a single platform
- execution of sophisticated motion tasks
- flexible scalability of hardware and software

► [www.beckhoff.com/battery-production](http://www.beckhoff.com/battery-production)



### Cell production: Rapid stacking of pouch cells

With our modular TwinCAT automation software, even highly sophisticated motion tasks in the stacking process of battery cells can be executed with real precision. On the hardware side, a large portfolio of drive technology is available in various performance classes.

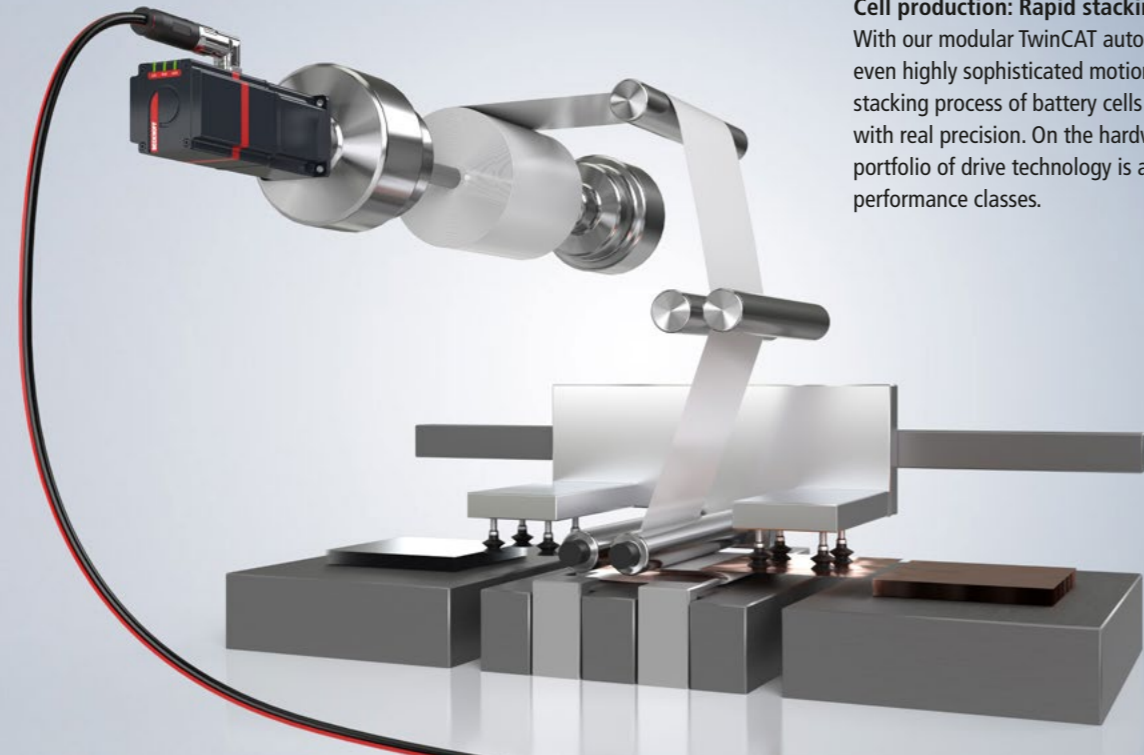

### Powerful robotics solutions for battery module and pack assembly

TwinCAT enables the control of all common robot kinematics with modular software libraries. Direct integration into the central control platform ensures maximum performance and efficiency.

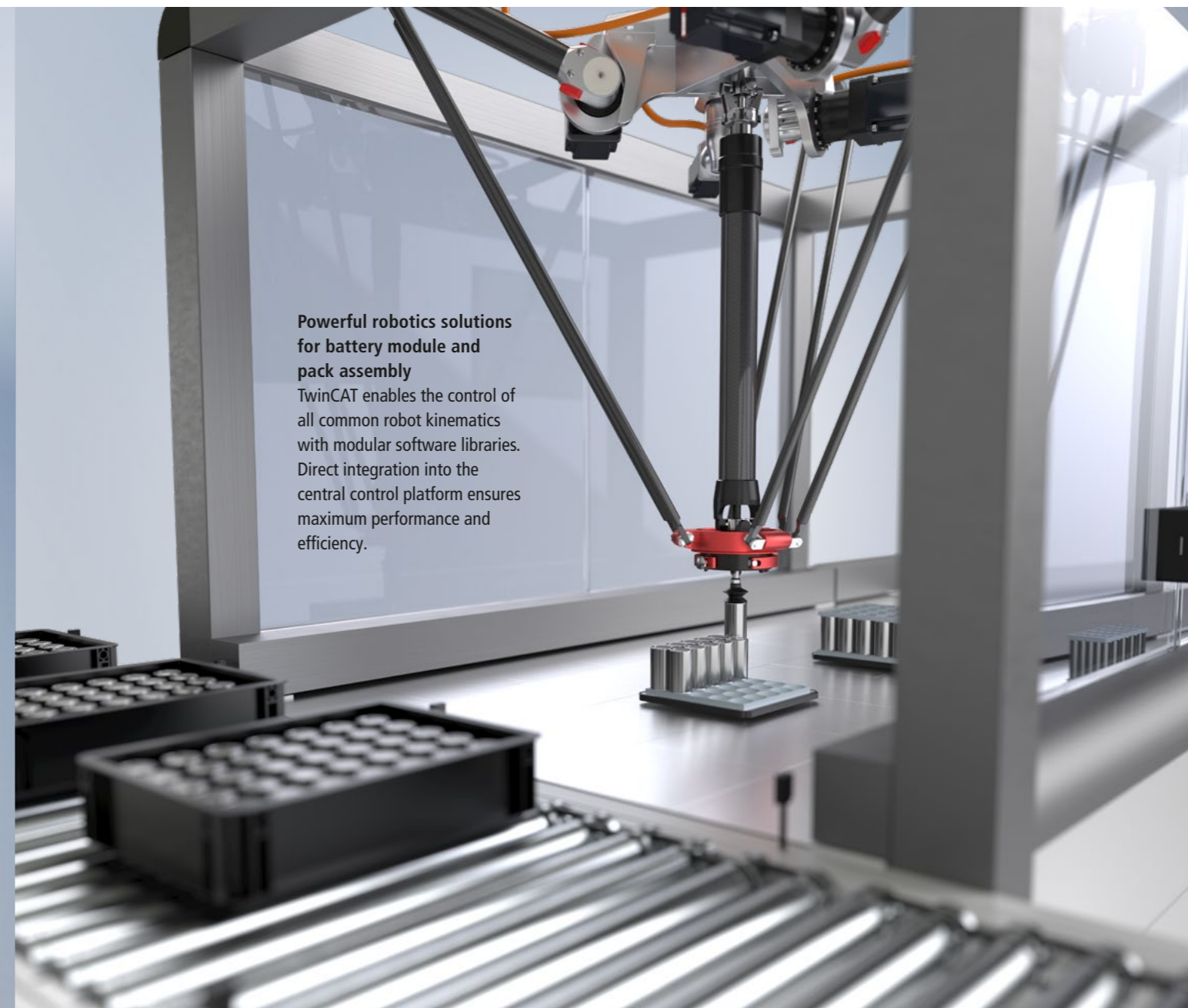

### Cell production: Safe electrolyte filling

We offer integrated automation solutions for hazardous areas: Process technology requirements can be implemented directly via the central control platform and integrated into real-time applications. An extended product range is available for use in potentially hazardous areas.

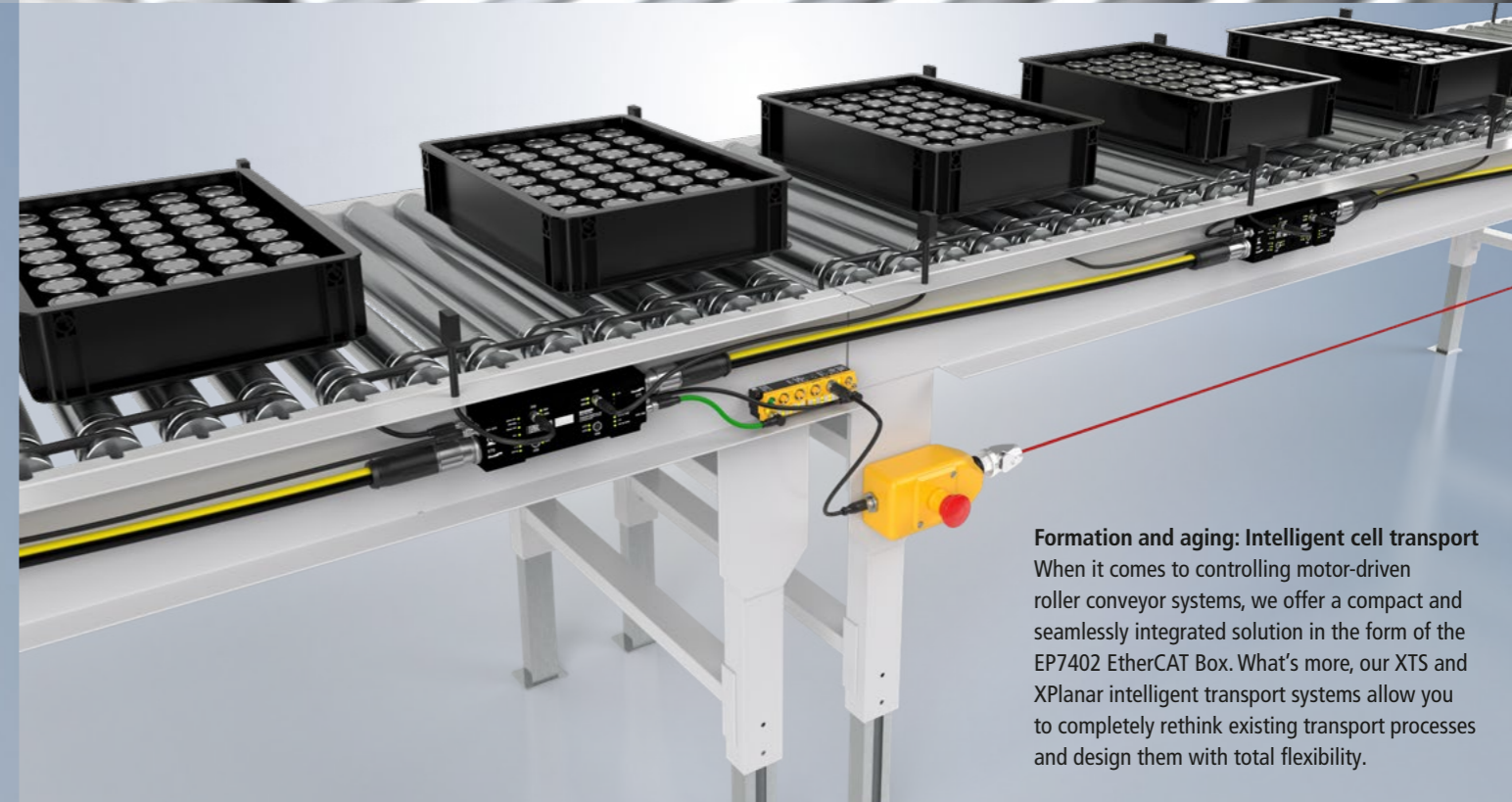
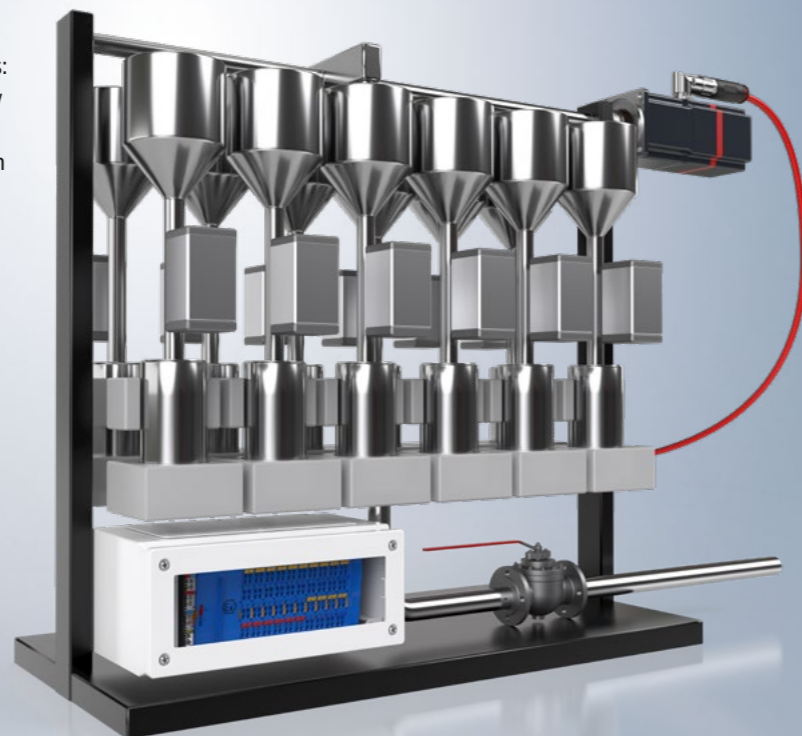

### Formation and aging: Intelligent cell transport

When it comes to controlling motor-driven roller conveyor systems, we offer a compact and seamlessly integrated solution in the form of the EP7402 EtherCAT Box. What's more, our XTS and XPlanar intelligent transport systems allow you to completely rethink existing transport processes and design them with total flexibility.

# TwinCAT integrates all control functions into software

TwinCAT automation software integrates all control functions, such as PLC, motion control, robotics, HMI, safety, analytics and vision, on a central platform using a uniform time base. TwinCAT serves as an end-to-end engineering and control platform and offers maximum flexibility and scalability with a wide range of modular software blocks, allowing you to select the modules you need for the task at hand and easily adapt them when functions are expanded.

The highly deterministic TwinCAT real time enables implementation of extremely fast processes with cycle times as fast as 50 µs, guaranteeing high machine output and synchronization. As pro-

cessor performance increases, cycle times will continue to fall in the future and enable even higher productivity – meaning that a control system from Beckhoff will also give you significant competitive advantages over the long term. The multi-core and many-core capability of TwinCAT 3 allow for execution of computationally intensive tasks, such as extensive data analyses or image processing, directly in the central control system without any performance losses. Support for all common software protocols ensures continuous communication up to the IT level. Simple connection to the cloud, ERP and other higher-level IT systems enables machines, factories or even entire

supply chains to be networked, optimizing process flows and production efficiency. TwinSAFE also enables full integration of safety technology into the central control platform. All safety requirements that apply in automotive production are met in full by the appropriate hardware and software components. Integration into the overall control system enables fast diagnostics and optimum synchronization with all control functions, boosting synergies and cost advantages.

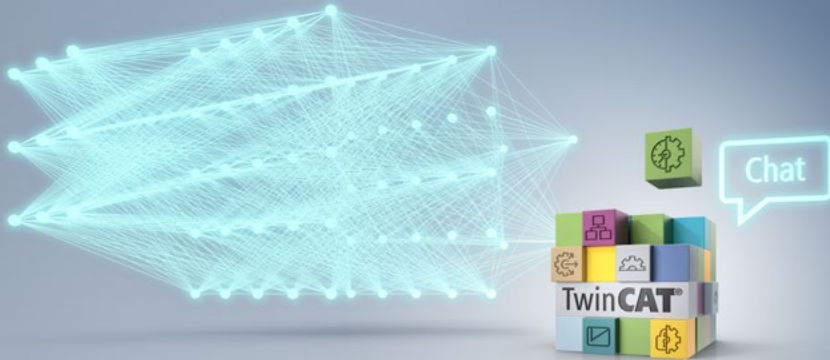

TwinCAT Chat now opens up the new world of chatbot possibilities for the automation environment.

ERP, MES, SCADA, Cloud, ...



**PLC**  
Implementation of one or more PLCs for real-time control

**TwinSAFE**  
Integration of safety technology into the control system

**XPlanar**  
Flexible control of XPlanar transport systems

**Analytics**  
Acquisition and evaluation of all relevant data

# Everything in one tool: TwinCAT simplifies engineering

As an integrated tool for engineering, runtime and modeling, TwinCAT simplifies the automation of sophisticated processes – so you only need one piece of software for programming and configuring your control system. Unified engineering in Visual Studio® enables software development, hardware parameterization and the integration of safety technology, while also making the commissioning process easier. In addition to the IEC 61131-3 programming standard, TwinCAT also supports C/C++ and MATLAB®/Simulink®, so you can choose the programming languages and tools best suited to your application. Open interfaces support expandability and adaptation to existing

tool landscapes. As a result, the integration of MATLAB®, LabVIEW™ or CAD tools enables development processes to run in parallel and shortens commissioning times. Integrating TwinCAT into Visual Studio®, with the integrated support of code administration tools like Git, allows automation objects to be programmed in parallel, simplifying project handling and collaboration in engineering teams. Curves can be displayed with microsecond resolution using TwinCAT 3 Scope. The software oscilloscope is fully integrated in the TwinCAT control architecture and enables the simple graphical display of signal curves using the charting tool.

Customer-friendly TwinCAT software licensing empowers engineers to select function libraries on a granular basis and continue to use them even when the hardware is changed. In the case of functional extensions or adjustments to the control system, subsequent licenses can be issued at any time. Software updates and support services are available free of charge.

## General TwinCAT benefits

- PC-based real-time control with IEC 61131-3 (incl. OOP extensions)
- powerful and flexible drive control
- one tool for all control tasks
- online view for variables in runtime
- engineering in Visual Studio®
- support for Windows and TwinCAT/BSD
- .NET integration in the same solution
- Git-based source code management
- runtime can be used directly on the workstation (e.g., a laptop)
- free engineering
- free runtime trial

## TwinCAT engineering tools

- configuration manager
- graphical TwinSAFE Editor
- EtherCAT network analysis tools
- event logger
- static code analysis
- cloud engineering
- knowledge base: [infosys.beckhoff.com](https://infosys.beckhoff.com)
- Drive Manager
- Motion Designer
- Cam Design Tool

The screenshot displays the TwinCAT development environment. On the left is the Solution Explorer showing a project structure for 'PLC\_Runtime\_851'. The main area is divided into several panes: a code editor showing C++ code for a sub-routine, a table of variable declarations, a ladder logic diagram for a communication module, and an Error List at the bottom. The Error List shows messages such as 'Keine Lizenz vorhanden!' and 'INVALID\_PARAMETER'.

| Expression   | Type  | Value          |
|--------------|-------|----------------|
| bInit        | BOOL  | TRUE           |
| fbTimerDelay | TON   | -249.764570... |
| fResult      | LREAL | -249.764570... |

This screenshot shows the TwinSAFE graphical editor, used for creating safety projects. It features a ladder logic diagram with safety-related components like safety relays and interlocks.

This screenshot displays the TwinCAT Scope tool, which provides a graphical interface for monitoring and analyzing signal waveforms in real-time.

This screenshot shows the TwinCAT HMI (Human-Machine Interface) environment, featuring a 3D model of a robotic arm and various control panels for operator interaction.

One tool for configuring the system and hardware

Writing the PLC program

Writing code in a C++ module









Creating an operator interface

# Scalable industrial PCs for all control applications

Powerful industrial PCs running TwinCAT form the central platform for PC-based control. You can select the best control system for your application from our extensive portfolio of control cabinet, embedded and panel PCs. Choose from all processor performance classes – from single-core to multi-core and many-core – plus all connection types, a range of display sizes and various form factors and protection ratings. We use standard CPUs and the latest processor technology to offer you maximum-performance control systems that will also provide you with the best possible equipment for future, computationally intensive tasks. With the scalability of our industrial PC portfolio,

however, you can also select the right device for lower-performance applications – meaning you only pay for the performance you actually need.

Since all our industrial PCs are manufactured in our own production facilities using scalable standard components and motherboards made in-house, the highest standards of quality and long-term availability are guaranteed. For instance, while individual PC series may be equipped with new processor generations over the years, the housing design remains unchanged and TwinCAT can be easily ported from an old device to a new one. This ensures investment protection and maximum availability.

| 2005  | 2007  | 2009  | 2010  | 2012  | 2014  | 2017  | 2020  | 2023  |
|---|---|---|---|---|---|---|---|---|
|  |  |  |  |  |  |  |  |  |
| <b>C6920-0000</b><br>Intel® Pentium® M  | <b>C6920-0010</b><br>Intel® Core™2 Duo  | <b>C6920-0020</b><br>Intel® Core™2 Duo  | <b>C6920-0030</b><br>Intel® Core™2 Duo  | <b>C6920-0040</b><br>3 <sup>rd</sup> generation Intel® Core™ i7                     | <b>C6920-0050</b><br>4 <sup>th</sup> generation Intel® Core™ i7                     | <b>C6920-0060</b><br>7 <sup>th</sup> generation Intel® Core™ i7                     | <b>C6920-0070</b><br>9 <sup>th</sup> generation Intel® Core™ i7                     | <b>C6920-0080</b><br>11 <sup>th</sup> generation Intel® Core™ i7                    |



C6015

C6017

C6025

C6027

C6030

C6032

C6040

C6043



# Robust panels and panel PCs – with customer-specific designs on request

As the front end of a machine, control panels are the visual and functional business card. As such, they not only need to be designed for use in industrial environments, but also need to be aesthetically pleasing and deliver user-friendly operation. With a comprehensive range of high-quality control panels and performance-scalable panel PCs, we offer state-of-the-art ease of use for a wide variety of application scenarios in automotive production – which means that optimized functionality and elegant design are guaranteed.

The housings for our control panels and panel PCs are essentially made from solid aluminum and offer IP65 ratings. The meticulous development

and integration of electronic parts, displays, touch screens and front laminates ensure high levels of availability and reliability in operation. Advanced multi-touch technology meets tried-and-tested housing technology and perfectly tuned PC hardware. A selection of connections and cable technologies are available for the connection between the control panel and industrial PC. The highly robust control panels and panel PCs from the CPX series also enable the devices to be used in zone 2/22 hazardous areas.

With our in-house production facilities and in-depth housing expertise, customer-specific solutions can also be created without the need for

extensive development work. Control panels can be individually designed and engineered, covering everything from visual adaptations such as a color scheme to suit the machine design and logos in the customer's corporate design, to adding customized equipment in the form of special buttons such as emergency stop buttons, scanners, or EKS RFID readers and modified mechanical and electrical connections, all the way through to fully customized housing designs. In addition to the design, the functionality of the control panels is of primary importance: as the central control element, they must ensure optimum operation of the machine or system.



Beckhoff IPC technology is used globally by the BMW Group – for example, panel PCs with a customer-specific push-button extension.

Your label

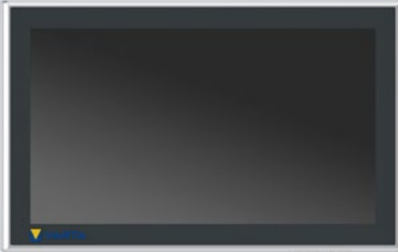

Your configuration

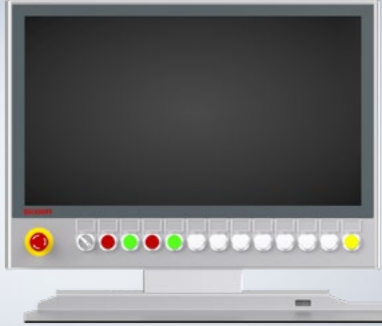

Your features



Your corporate design

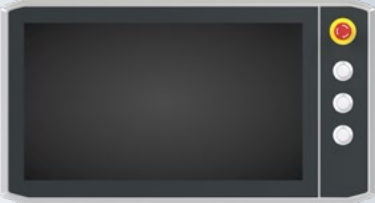

# Safety, explosion protection, measurement technology: Integrated with EtherCAT

With around 1000 I/Os for more than 100 signal types, Beckhoff offers an extensive modular automation toolkit with fieldbus components for all common I/Os and bus systems. You can flexibly assemble the ideal components for your control architecture – of course, with the option for future functional expansions. An extensive range of I/O housing formats, a variety of channel densities and flexible interfaces ensure that the ideal product is available for every application scenario.

In addition to standard functionalities, our I/O portfolio includes products for specialized applications, such as safety technology, explosion protection, measurement technology and the control of

small motors via drive technology. Communication and power measurement terminals for charging infrastructure are also available. By combining a wide variety of I/O components, all control tasks can be centrally integrated on one platform. This significantly reduces the complexity of your control system – and what's more, a complete solution can deliver considerable advantages in terms of efficiency when compared to stand-alone solutions.

The I/Os are connected as standard via the high-speed EtherCAT fieldbus developed by Beckhoff. With outstanding performance, flexible topology selection, comprehensive diagnostics and simple configuration, EtherCAT is the fastest bus system on

the market and ideally suited for use in automotive production facilities. With EtherCAT, telegrams are transmitted without prioritization; no switch technology is required. The one cable solution EtherCAT P, which combines communication and power supply in one cable, reduces the cabling effort and enables control cabinet-free machine concepts. For machine mountable installation, EtherCAT Box modules are available in an IP67 design – including in highly robust stainless steel or zinc die-cast housings for welding applications.

A large number of EtherCAT-compatible sensors and actuators are available due to EtherCAT's high level of acceptance on the market. However, our con-

trol technology is also open with regard to the integration of other fieldbus systems. Support for common communication protocols, such as CANopen, IO-Link, PROFINET or Modbus, gives you maximum freedom in control design, even when it comes to retrofits or conversions of existing systems. The connection can be established using appropriate fieldbus couplers as well as embedded PCs, depending on the application and control topology. The Beckhoff I/O portfolio's high level of connectivity, maximum functional diversity and long-term availability offer secure investment protection: All of our bus terminals from over 26 years of development are still available and are compatible with all new EtherCAT Terminals.

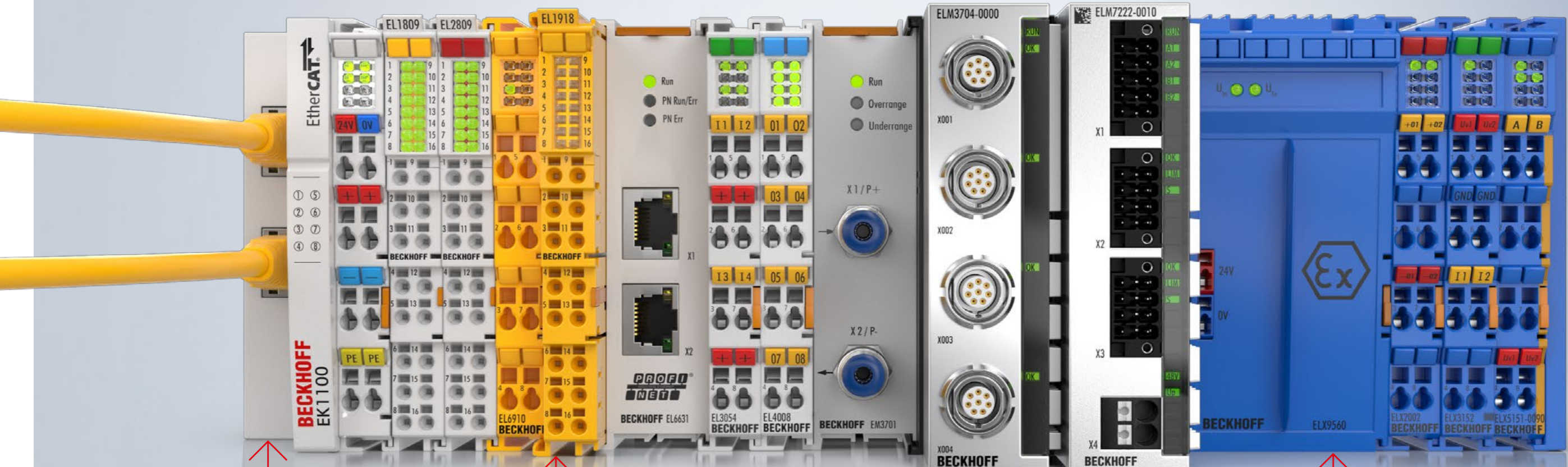

**Fieldbus couplers**  
 Connection of sensors and actuators – via EtherCAT or any other common communication protocols

**Safety**  
 Integration of functional safety into the control system with TwinSAFE

**Measurement technology**  
 ELM modules in metal housings for precision and high-speed measurement technology

**Explosion protection**  
 Highly compact I/O modules with integrated safety barriers for the direct connection of intrinsically safe field devices

# Highly scalable drive technology for all motion-related tasks

Our wide range of scalable drive technology components enables perfectly tailored solutions for drive concepts in all price and performance classes. The motion control solutions in TwinCAT automation software are complemented by an extensive range of servomotors and drive controllers, ranging from compact servo drives in I/O terminal format through to powerful servo drives for highly dynamic positioning tasks. For example, the integrated and high-performance control technology used in the AX8000 multi-axis servo system is ideally suited for robotic and material handling tasks to dynamically coordinate and position numerous axes. The servomotors are connected

using space-saving One Cable Technology, which combines the motor power and feedback lines in a single cable. With the option of integrated safety technology, our drive portfolio meets strict machine safety requirements and therefore makes it easier to configure control systems. Decentralized servo drive systems, such as the AMP8000 and AMI8100, in conjunction with the EtherCAT P one cable solution, are breaking new ground in modular, cabinetless machine concepts. The integration of the servo drive into the servomotor enables mounting directly on the machine. This reduces machine footprint and the complexity of your system, and leads to signifi-

cant savings in materials, cost and control cabinet space requirements. Our product range is complemented by intelligent and flexible transport systems. The XTS linear transport system and the XPlanar planar motor system replace rigidly timed product transport systems and pave the way for new agile machine concepts. Offering maximum speed and flexibility, they create a clear advantage in global competition. The space-saving design of these technologies reduces your machine footprint. What's more, there are no limits to the innovation you can bring to your machine and production designs.



**TwinCAT 3 Autotuning**  
Autotuning represents the simple commissioning and optimization of servo axes in machines. At the push of a button, the servo drive determines all essential parameters of the application within seconds. TwinCAT 3 Autotuning simplifies the commissioning of servo axes through automated interpretation of stability criteria and characteristics, especially for phase and amplitude.

Drive technology



Linear motor

Compact drive technology

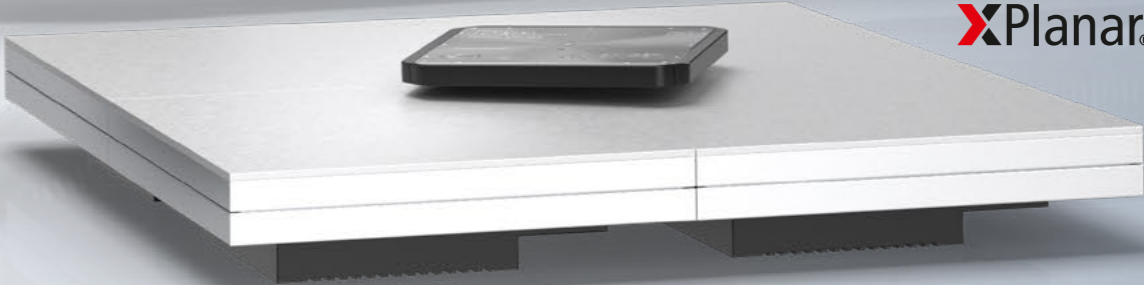

XTS®

XPlanar®

# Pluggable system solution for control cabinet-free automation

For the first time, the MX-System enables completely control cabinet-free automation solutions in machine and system engineering through a comprehensive, modular, and pluggable IP67 system. The composite of baseplate and function modules resulting from the modular system combines all tasks and features of a control cabinet from the power supply to the connection level for the field devices. The full system integration of all machine functionalities is achieved via freely selectable IPC, coupler, I/O, drive, relay, and system modules, which can be configured and combined according to the specific application.

The consistently systemic approach of comprehensively coordinated assemblies enormously reduces the effort required for planning, assembly, machine installation, and maintenance. Since considerably fewer components are required than in traditional control cabinet design to implement the same requirements, the entire MX-System is significantly more compact than previous solutions. The system footprint is reduced, and system availability and flexibility are also increased. In each life cycle phase of a control system, the MX-System offers significant advantages over the classic control cabinet.

The possible uses of the MX-System are highly flexible and can be precisely adapted to suit the requirements of any application. On the one hand, the MX-System can be used as a stand-alone solution for complete plant automation. With the help of the corresponding system modules, cascaded system structures in different topologies can easily be created. This also makes it possible to implement decentralized automation solutions that are specially adapted to suit each application. On the other hand, the MX-System can be connected to conventional automation components via industry-typical communication interfaces so that the aforementioned advantages also come into play in existing plants.

## MX-System

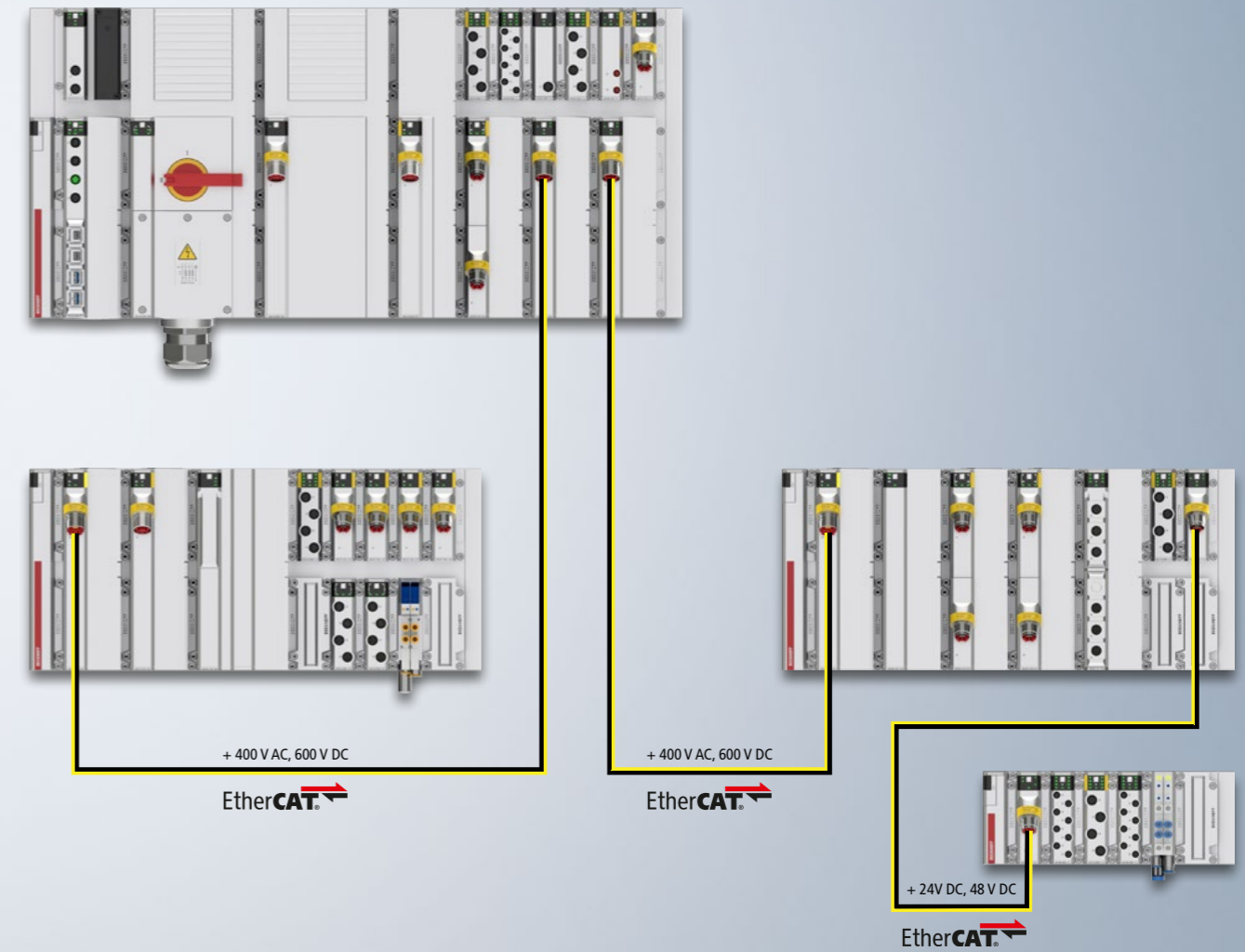
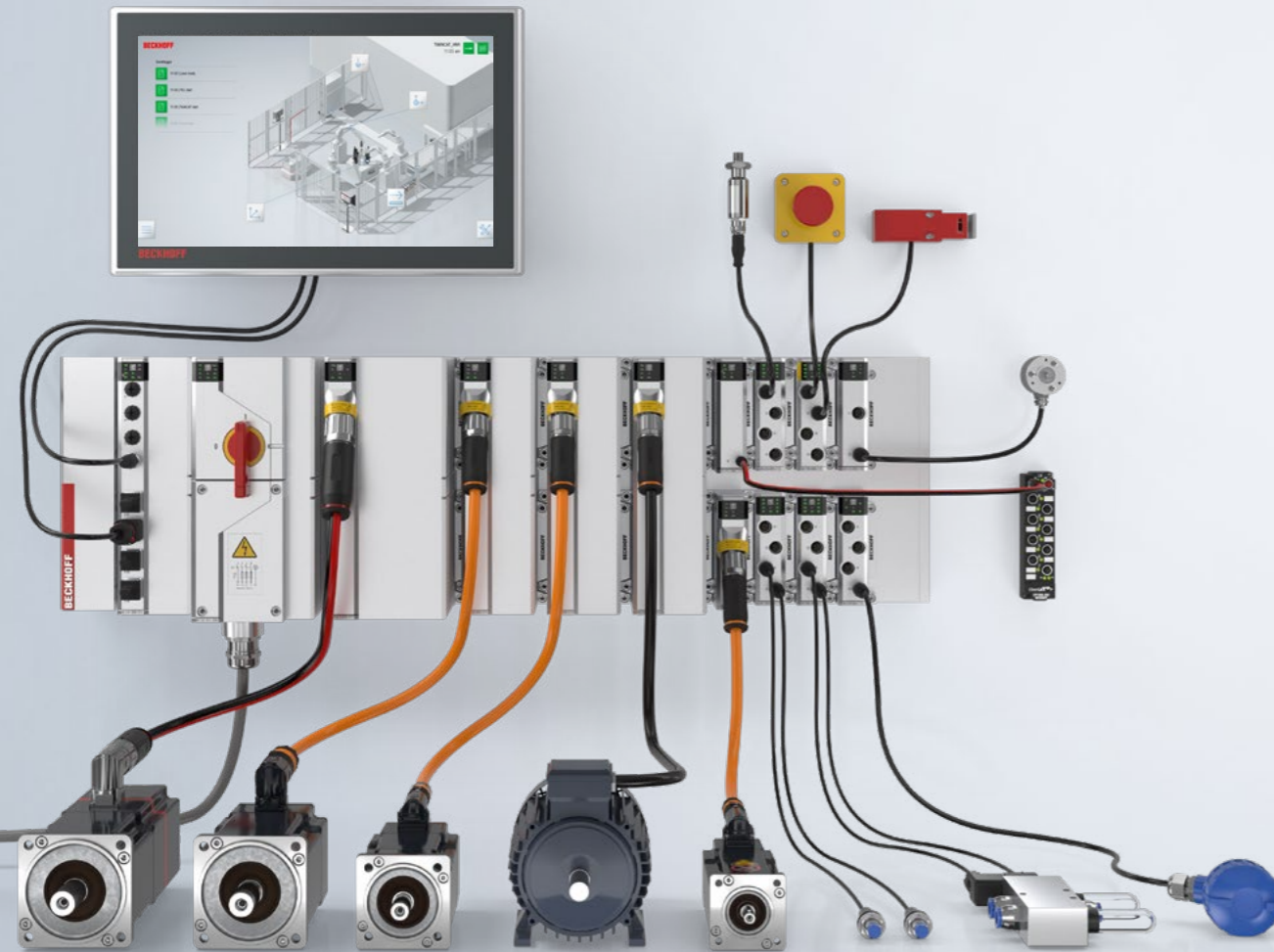

# Decentral machine and plant concepts

**Motor controller box**  
IP67 EtherCAT box as controller for motor-driven roller conveyor systems

**Vision**  
Complete vision system consisting of hardware and software for industrial use

**Distributed servo drive system**  
Servo motors with integrated servo drive for the realization of modular machine concepts

**IP65 Panel PC**  
Panel PCs in IP65 combine modern touch technologies and flexible computing power.

# Cabinetless machine and plant concepts

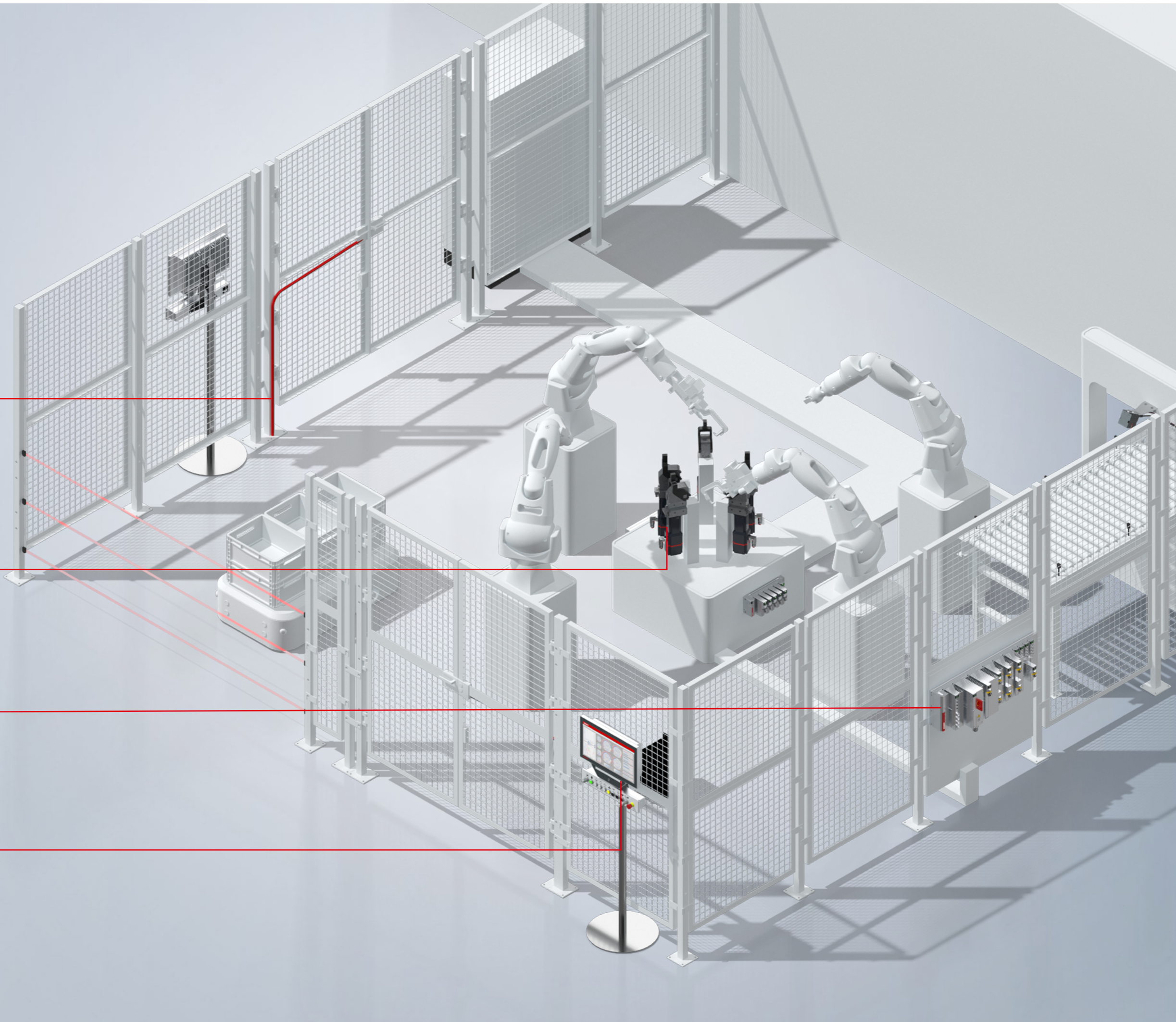

## EtherCAT P

One cable solution combines communication and power in a standard Ethernet cable and reduces the wiring effort.

## Distributed servo drive system

Servo motors with integrated servo drive for the realization of modular machine concepts

## MX-System

Pluggable system solution in IP67 for control cabinet-free automation

## One Cable Display Link

CP-Link 4 one cable solution combines communication and power for the connection of panels and panel PCs.

# Automation solutions for flexible system engineering

With our flexible and scalable control technology, you can build modular machines that perfectly suit the system type and application scenario at hand. Simply select the components from our modular automation toolkit that are best suited to your machine type in terms of scale, complexity and environmental conditions.

The ultra-compact C60xx series industrial PCs are available for space-saving solutions. They offer maximum performance in the smallest possible format with a wide range of options for control cabinet installation. The compact servo drives in the AMI series integrate a servomotor, servo drive and fieldbus connection in a space-saving design.

They can be mounted directly on the machine, minimizing the space required in control cabinets.

High-performance motion tasks can be implemented with the AMP8000 distributed servo drive system, for example. It integrates a highly efficient servo drive directly into the motor, enabling modular machine designs for even more sophisticated systems. The one cable solution EtherCAT P is used for the connection; by combining the power supply and signal transmission with EtherCAT, this solution reduces the amount of cabling and maintenance work required.

As the EtherCAT Box modules are IP67-rated, the sensor and actuator technology can also be

relocated directly to the machine. The decentralized integration of the I/Os into the machine design makes it easy to introduce extensions and configuration changes. Our motion control solutions are also characterized by a high degree of flexibility. The centralized software approach makes it easy to add or adapt axes. Even complex motion sequences such as flying saw and cam plates can be combined as required – for example, with the AX8000 multi-axis servo system.

The complete vision portfolio with cameras, optics, illumination and software enables the seamless integration of industrial image processing into the control system.

The EJ series of EtherCAT plug-in modules offers a solution for machines and equipment produced in high volumes. These circuit board mounted modules are based on EtherCAT Terminals and offer the same broad variety of signals. Their electromechanical design enables them to be plugged directly into an application-specific signal distribution board, from which the wiring is continued via connectors with pre-assembled cables. Many other components that would otherwise be installed in the control cabinet are housed as plug-in modules on the board. This makes it possible to reduce both space requirements and commissioning costs, especially in series production.

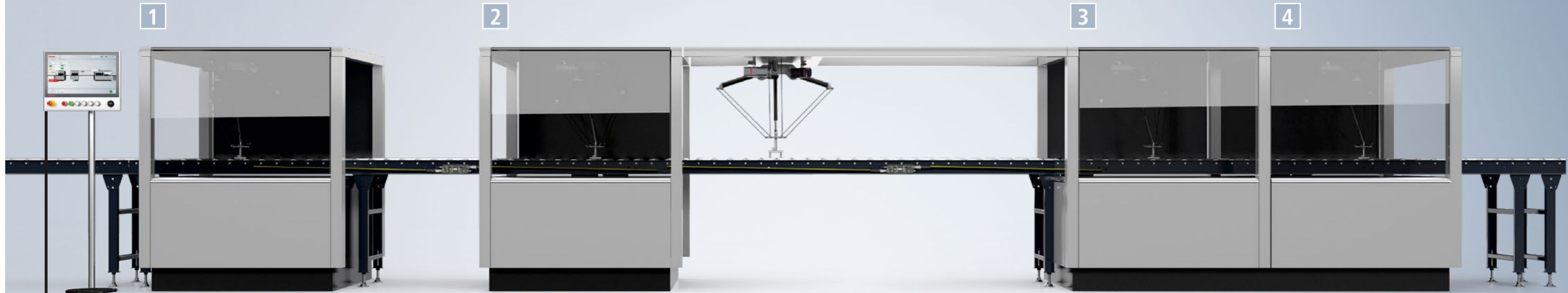

CP-Link 4

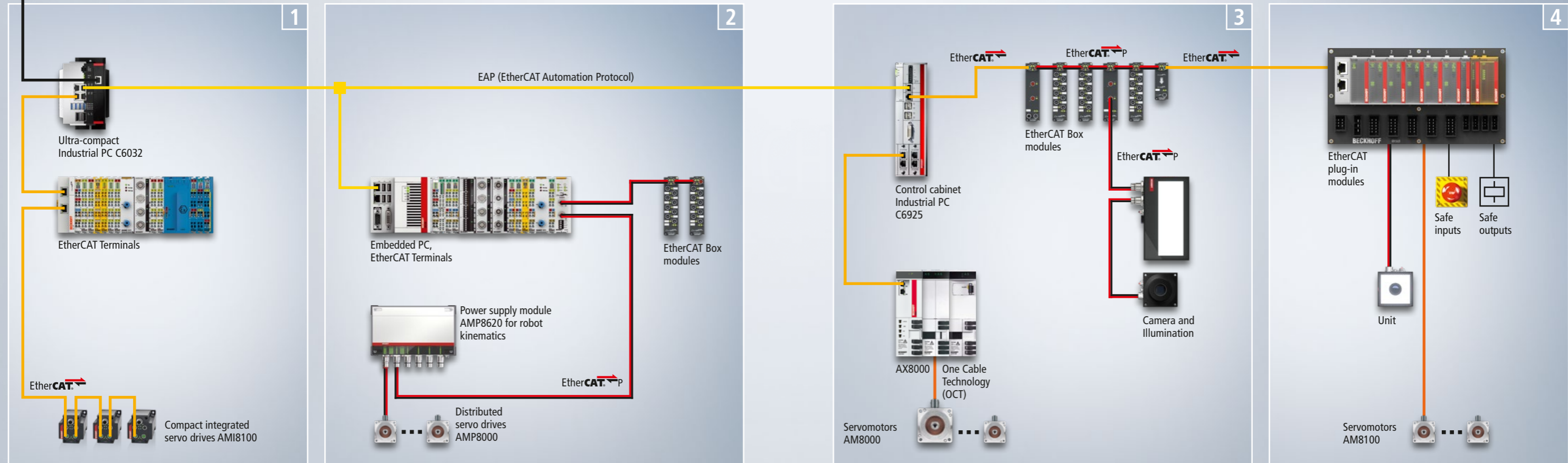

# PC-based control integrates all control functions

Management level  
Field/control level

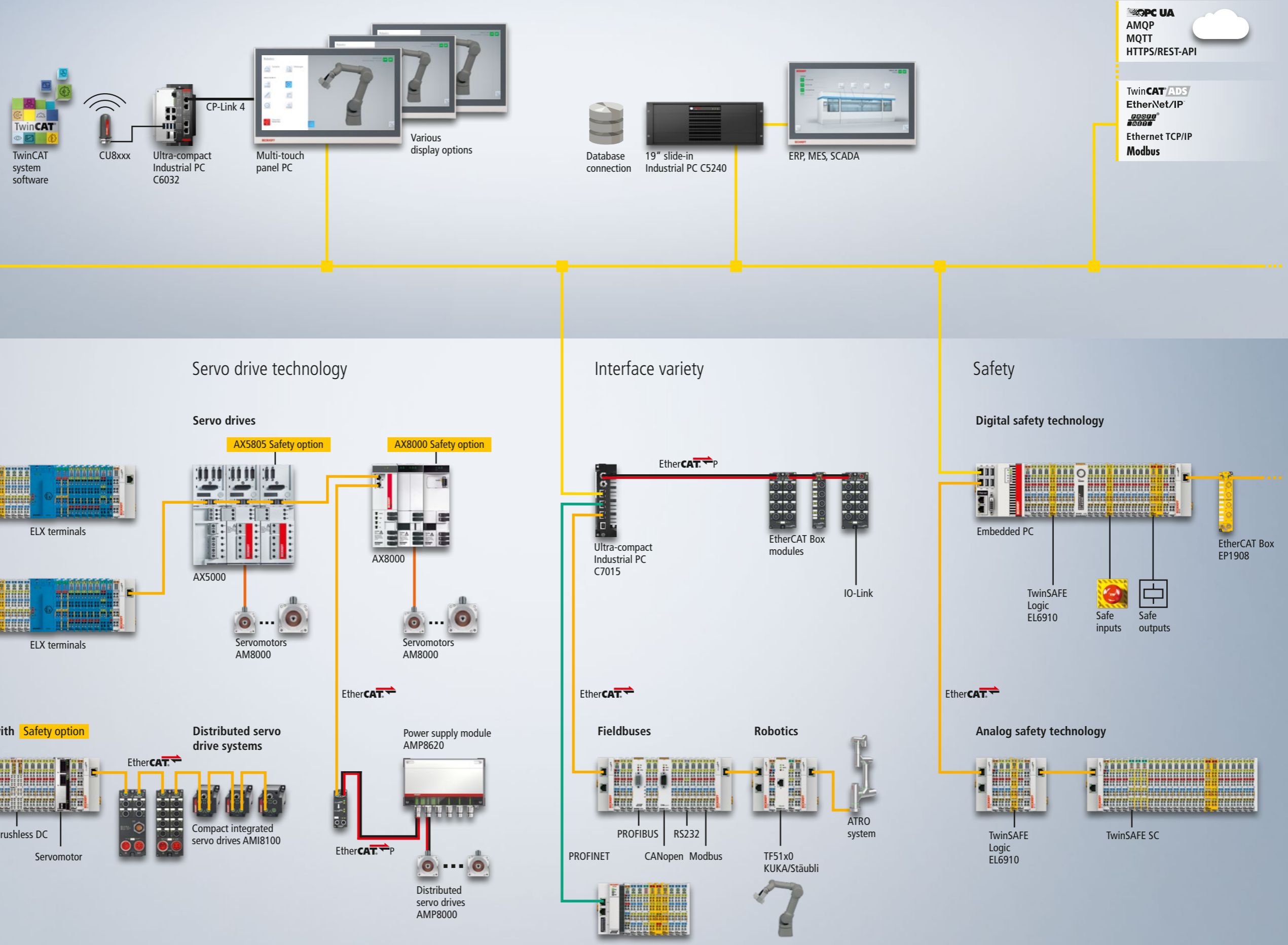



# Our references



**Manz AG, Germany**

PC-based control optimizes laser welding system for the production of lithium-ion battery modules.

► [www.manz.com](http://www.manz.com)



© Beckhoff



**Sonplas GmbH, Germany**

High-speed rotary transfer machine for pre-assembly of stators with PC-based control technology, efficiently programmed with TwinCAT

► [www.sonplas.com](http://www.sonplas.com)



© Sonplas



**Nel Hydrogen, Denmark**

Real-time control of hydrogen filling stations

► [www.nelhydrogen.com](http://www.nelhydrogen.com)



© Beckhoff

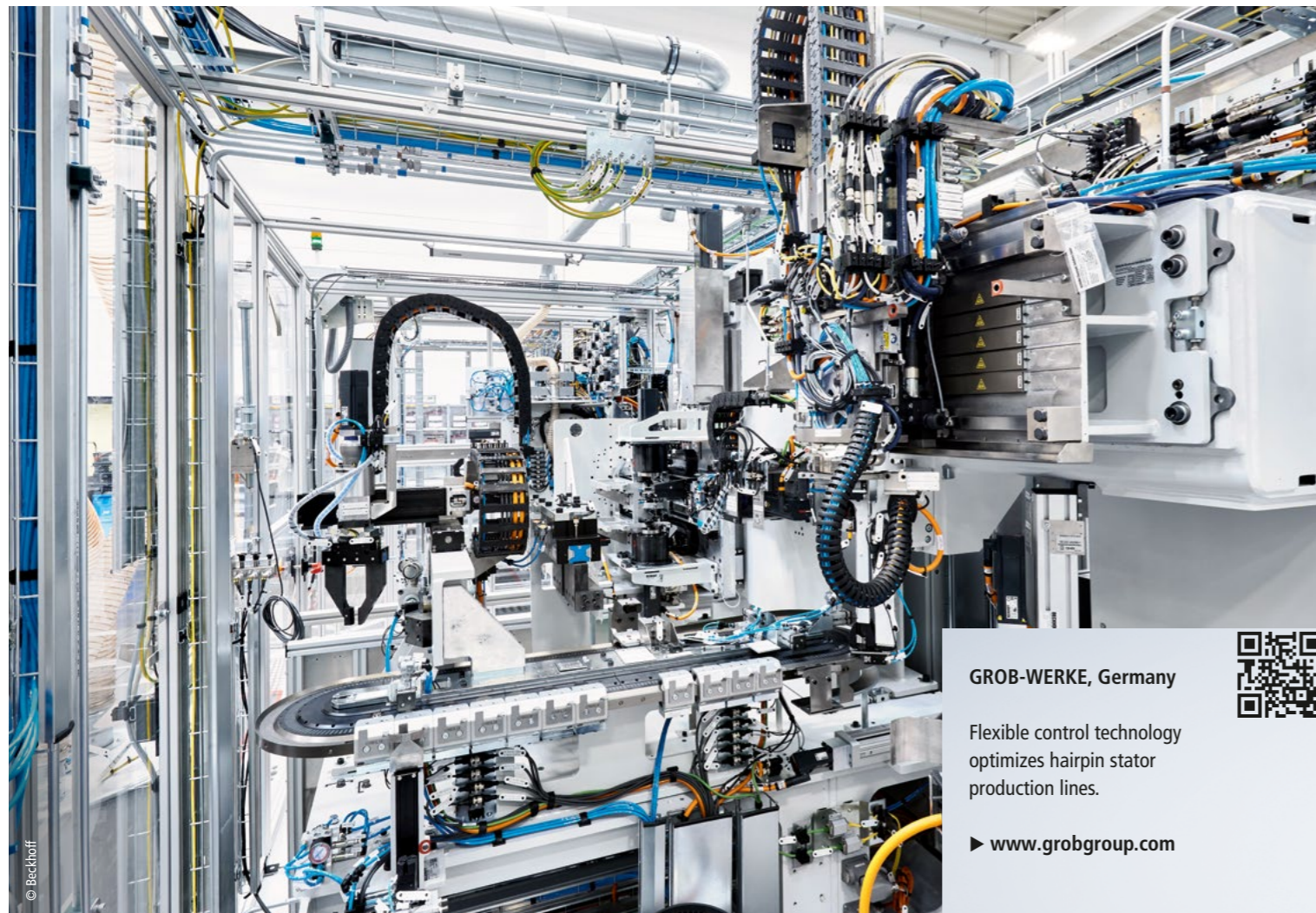

**GROB-WERKE, Germany**

Flexible control technology optimizes hairpin stator production lines.

► [www.grobgroup.com](http://www.grobgroup.com)



© Beckhoff

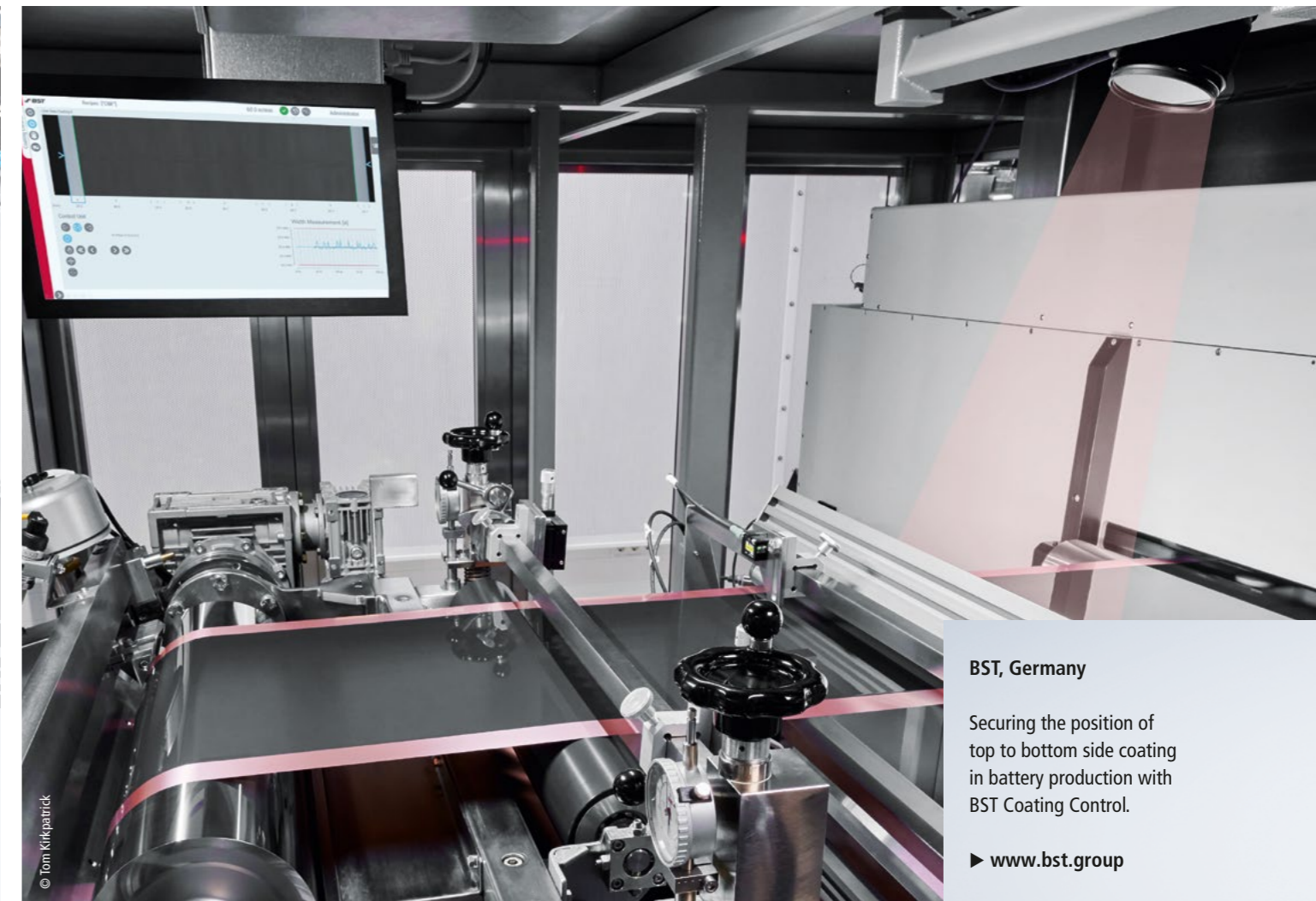

**BST, Germany**

Securing the position of top to bottom side coating in battery production with BST Coating Control.

► [www.bst.group](http://www.bst.group)

© Tom Kirkpatrick

# Our references



Stoba, Germany

XPlanar in deep-learning-based optical component inspection in the automotive segment

► [www.stoba.one](http://www.stoba.one)



© Beckhoff

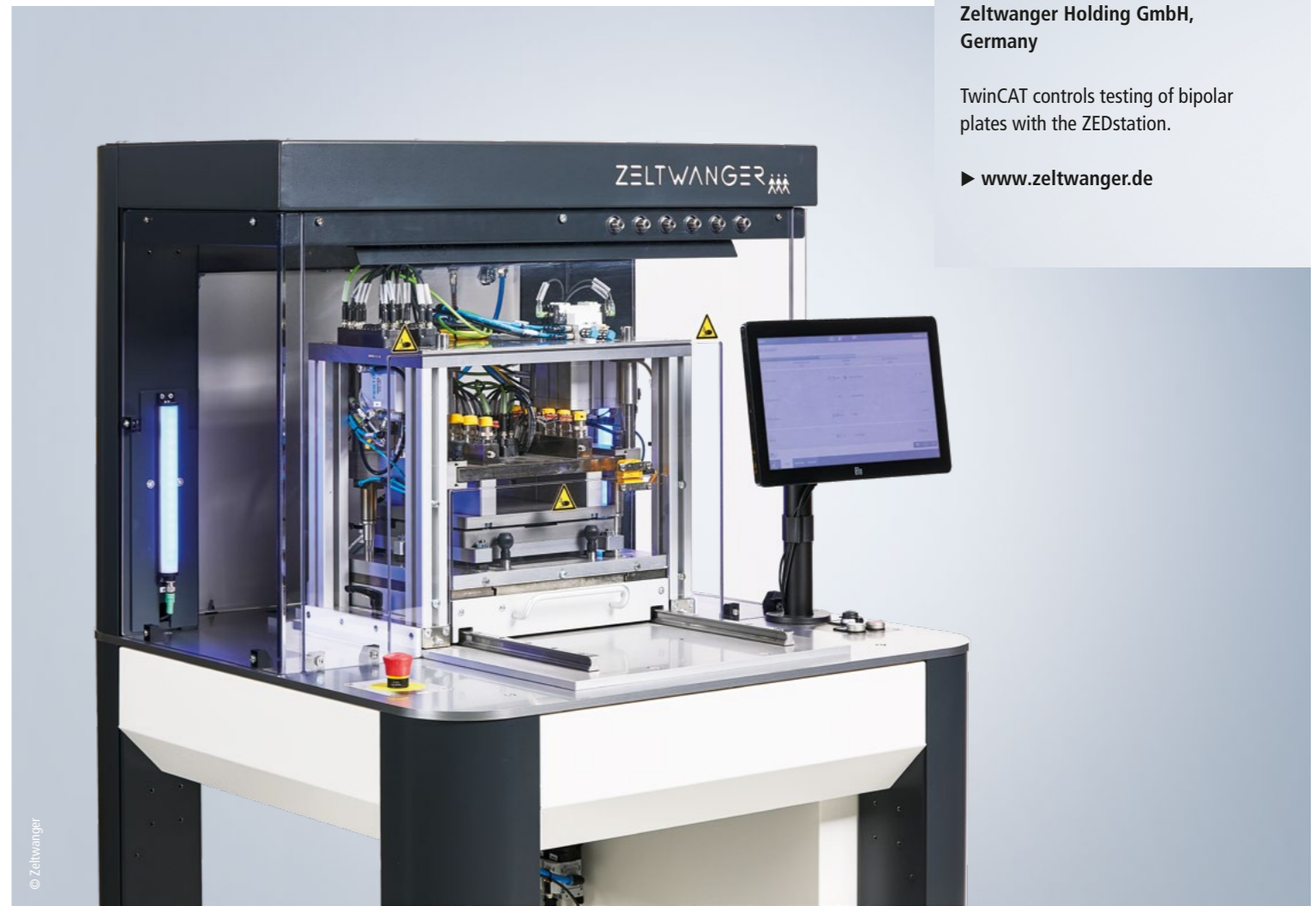

Zeltwanger Holding GmbH, Germany

TwinCAT controls testing of bipolar plates with the ZEDstation.

► [www.zeltwanger.de](http://www.zeltwanger.de)

© Zeltwanger



Schuler Group, Germany

Fully automatic press lines

► [www.schulergroup.com](http://www.schulergroup.com)

© Schuler Group



HS Kempten and ABT, Germany

Fast and flexible test bench technology for vehicles converted to electric drives

► [www.abt-eline.com](http://www.abt-eline.com)  
 ► [www.hs-kempten.de/en/research](http://www.hs-kempten.de/en/research)



© Beckhoff



Trumpf, Germany

Highly adaptable automation for 3D laser cutting systems

► [www.trumpf.com](http://www.trumpf.com)



© Trumpf GmbH + Co. KG/Oliver Graf Fotostudio GmbH

# Our references



**bdtronic GmbH, Germany**

Automation technology from Beckhoff controls dispensing machines for the production of battery cells.

► [www.bdtronic.com](http://www.bdtronic.com)

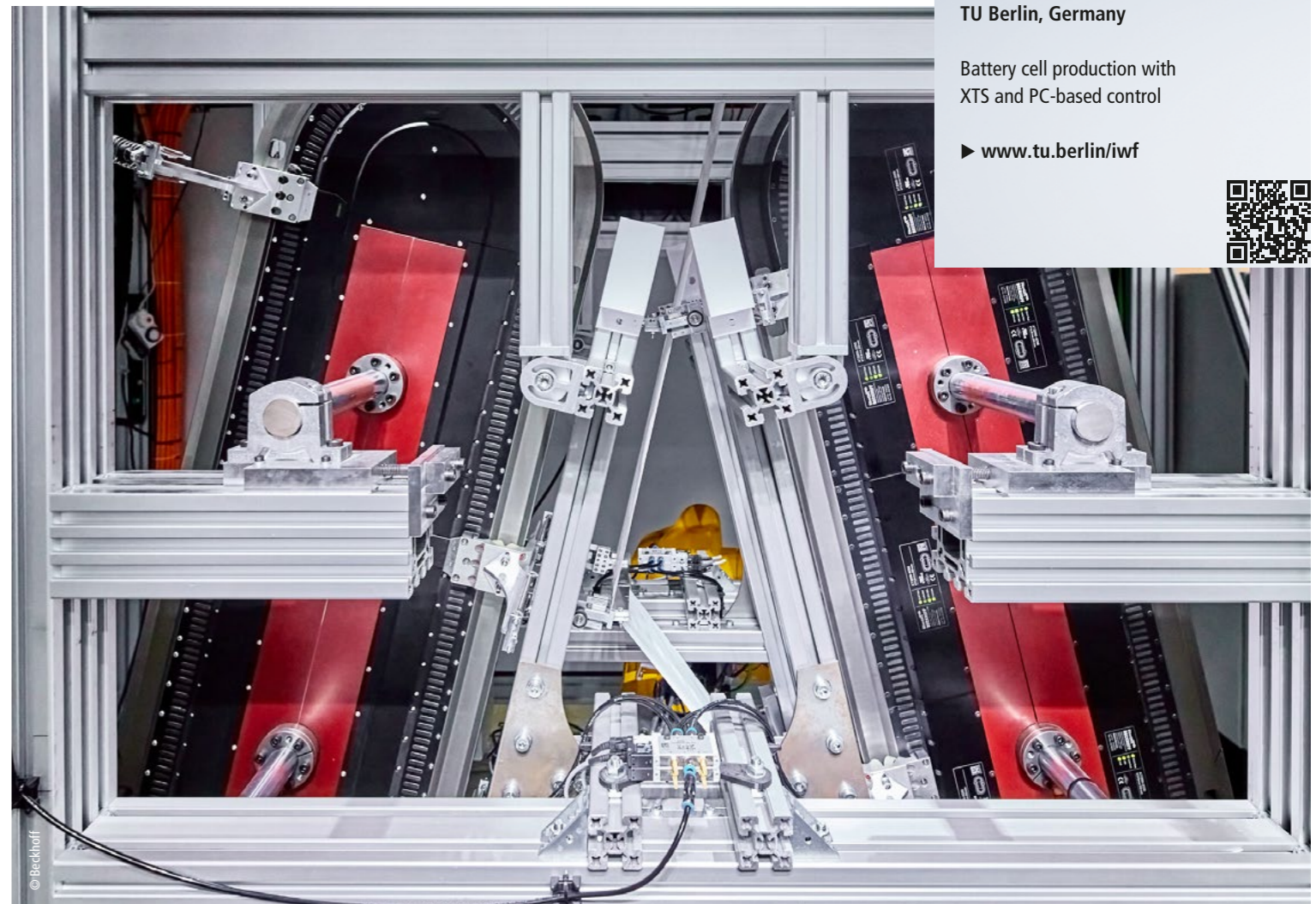

**TU Berlin, Germany**

Battery cell production with XTS and PC-based control

► [www.tu.berlin/iwf](http://www.tu.berlin/iwf)

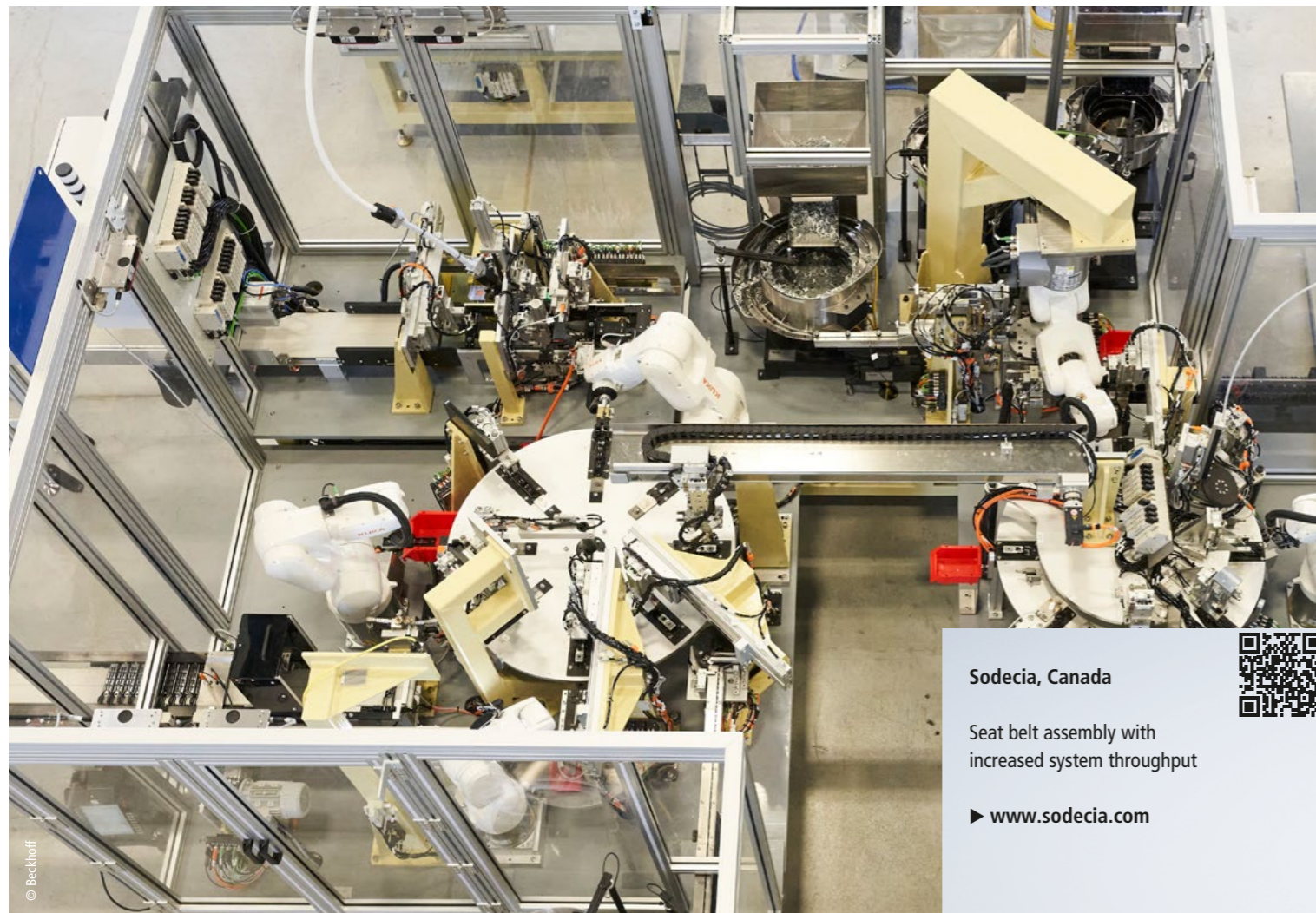

**Sodecia, Canada**

Seat belt assembly with increased system throughput

► [www.sodecia.com](http://www.sodecia.com)



**Thyssenkrupp Presta, Liechtenstein**

Precision measurement terminals in the final inspection of steering systems

► [www.thyssenkrupp-presta.com](http://www.thyssenkrupp-presta.com)



**S4 International, South Africa**

Beckhoff control technology automates battery cell testing and sorting.

► [www.s4international.de](http://www.s4international.de)

# Our references



**Gefasoft, Germany**  
 XTS enables parallel inspection processes of diffusers for car airbags.  
 ▶ [www.gefasoft.com](http://www.gefasoft.com)



**Continental Reifen, Germany**  
 Integrated control technology in the tire industry  
 ▶ [www.continental-tires.com](http://www.continental-tires.com)

© Continental Reifen Deutschland GmbH, ComiLifeCycle™



**Plasmatreat GmbH, Germany**  
 XPlanar simplifies transportation of sensitive workpieces.  
 ▶ [www.plasmatreat.com](http://www.plasmatreat.com)



© Plasmatreat, Jan Dufelsiek



**CIS Co., Ltd, Republic of Korea**  
 Beckhoff technology optimizes slitter in battery production line.  
 ▶ <http://www.cisro.co.kr/en/main.html>

© CIS



**COWINTECH Co., Ltd., Republic of Korea**  
 Pre-material transport for battery production with a fully automated AGV  
 ▶ [www.cowintech.com/en](http://www.cowintech.com/en)

© COWINTECH Co., Ltd.

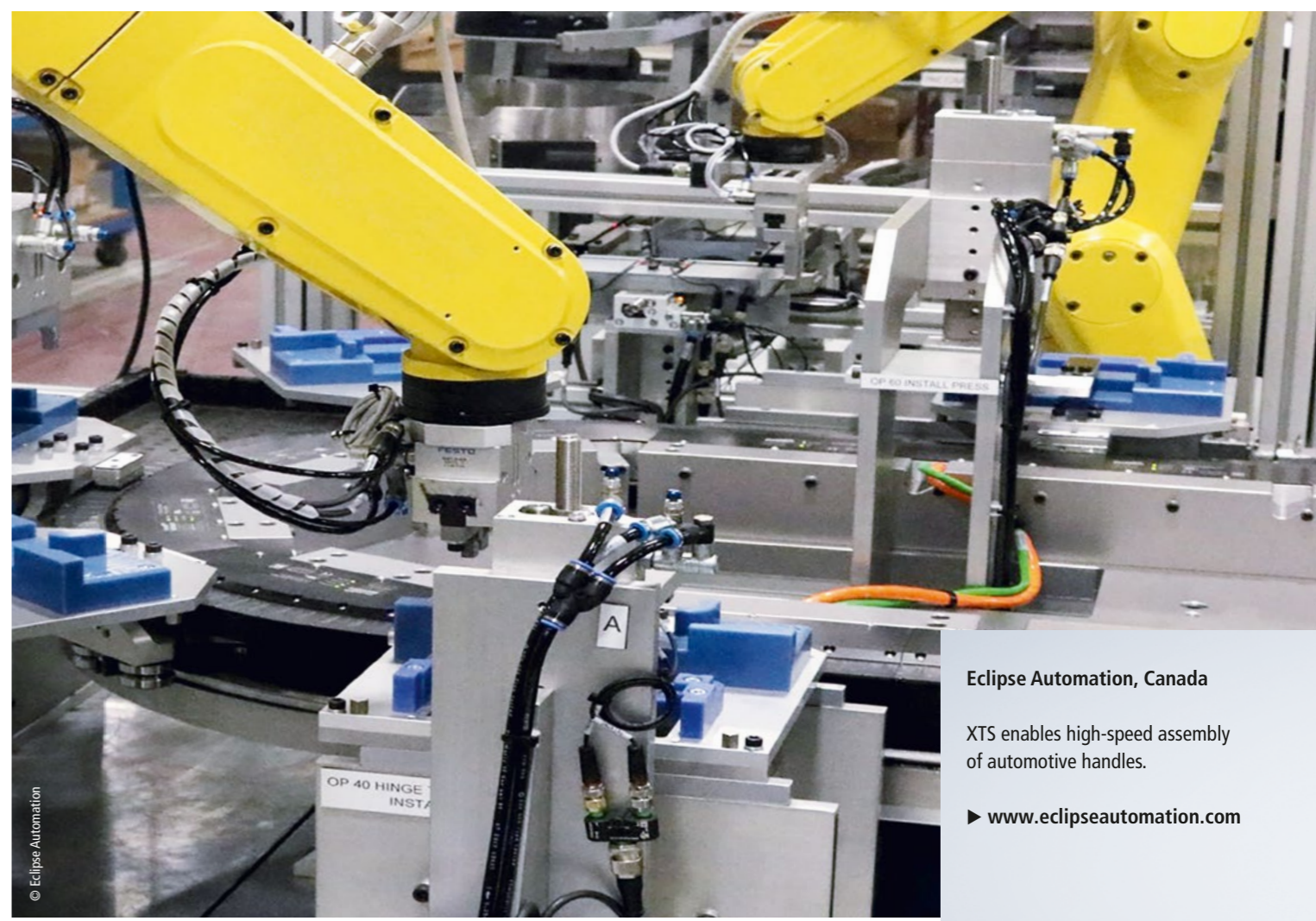

**Eclipse Automation, Canada**  
 XTS enables high-speed assembly of automotive handles.  
 ▶ [www.eclipseautomation.com](http://www.eclipseautomation.com)

© Eclipse Automation



## More about Beckhoff



Company



Global presence



Events & dates



Jobs



Products



Industries



Support

### Beckhoff Automation GmbH & Co. KG

Hülshorstweg 20

33415 Verl

Germany

Phone: + 49 5246 963-0

info@beckhoff.com

www.beckhoff.com

Beckhoff®, TwinCAT®, TwinCAT/BSD®, TC/BSD®, EtherCAT®, EtherCAT G®, EtherCAT G10®, EtherCAT P®, Safety over EtherCAT®, TwinSAFE®, XFC®, XTS® and XPlanar® are registered trademarks of and licensed by Beckhoff Automation GmbH. Other designations used in this publication may be trademarks whose use by third parties for their own purposes could violate the rights of the owners.

© Beckhoff Automation GmbH & Co. KG 06/2024

The information provided in this brochure contains merely general descriptions or characteristics of performance which in case of actual application do not always apply as described or which may change as a result of further development of the products. An obligation to provide the respective characteristics shall only exist if expressly agreed in the terms of contract.

We reserve the right to make technical changes.